

Line Construction Hardware

POLE BAND, DOUBLE MOUNTING, 5"-5-1/2" POLE DIA.

#HW-PLA5

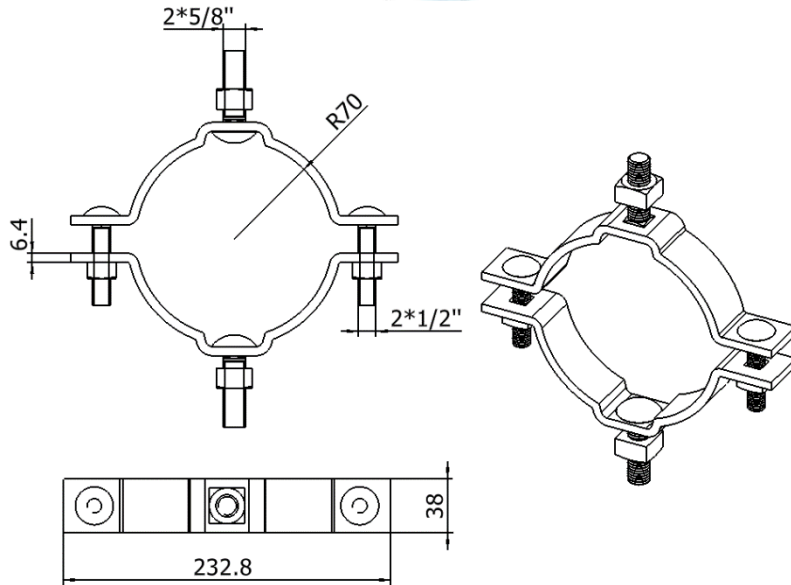



This multi-piece pole band provides a solid and secure mounting foundation for aerial fiber optic hardware. Its adjustable structure ensures a tight fit around concrete, wood, or steel utility poles, making it an essential component for FTTH and telecommunication deployments.

FEATURES

- Hot dip galvanized per ASTM A153
- Includes two 1/2" bolts for clamping band halves
- Two 5/8" carriage bolt for attachment

SPECIFICATIONS

Items 	Specs 
Material	Hot-dip galvanized steel
Overall Dimension	232.8*38 mm
Bolt Size	2*5/8" & 2*1/2"
Compatible Pole Diameter	5" – 5 1/2"
Weight	1,550 g